

# JUNIPER<sup>®</sup> AXIS T Remote Installation Guide

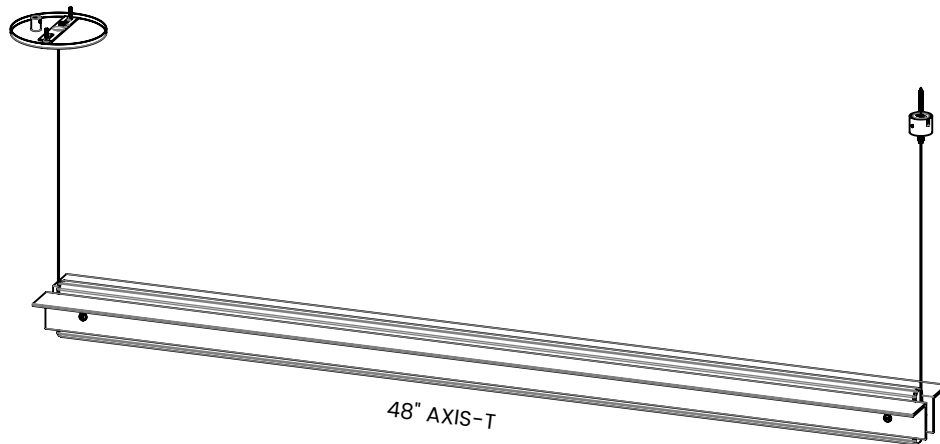
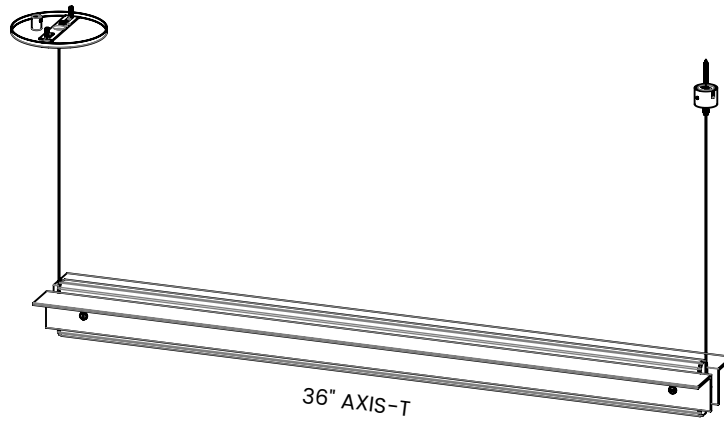

**WARNING**

**A LICENSED ELECTRICIAN SHOULD PERFORM INSTALLATION. DISCONNECT MAIN POWER AT THE SOURCE PRIOR TO INSTALLATION.**

**INSTRUCTIONS MEANT FOR REMOTE CLASS 2 DRIVER(S).**

**DUE TO HEAVY WEIGHT OF THE FIXTURE, EXTRA CAUTION IS REQUIRED WHEN HANDLING. PREFERABLY, TWO PEOPLE SHOULD BE INVOLVED IN THE INSTALLATION OF THE FIXTURE.**

**STEP 1: MARK MOUNTING POINTS**

Carefully mark the mounting points, using the spacing in Figure 1. **It is highly recommended to use a laser alignment/measuring tool to ensure that mounting points are properly distanced.**

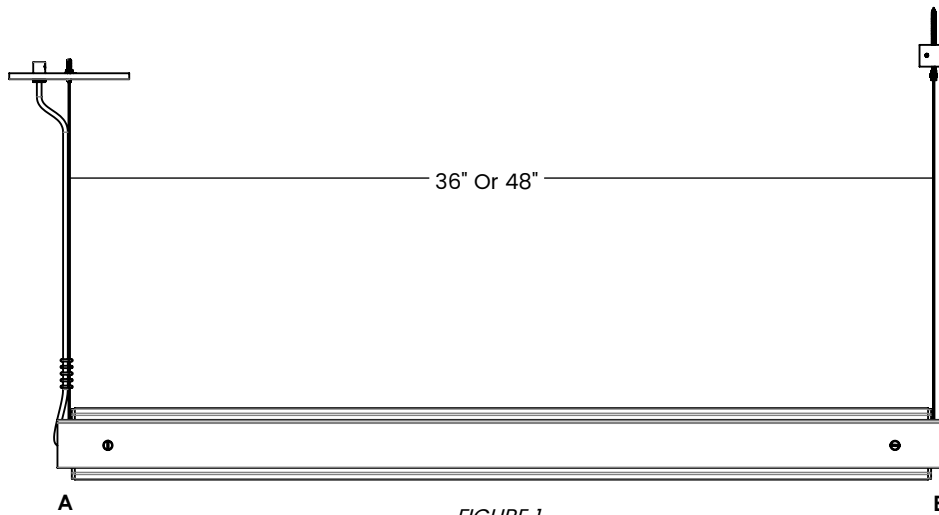

FIGURE 1

**KEY**

**A POWER END** CANOPY PLATE IS MOUNTED AT POWERED END OF THE FIXTURE.

**B CEILING POST** MOUNTED AT THE NON-POWERED END OF THE FIXTURE.

**STEP 2: FIXTURE INSTALLATION**

**POWER END (A)**

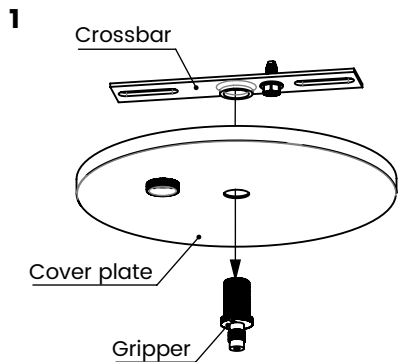

FIGURE 2

Remove gripper from the cover plate to release the crossbar.

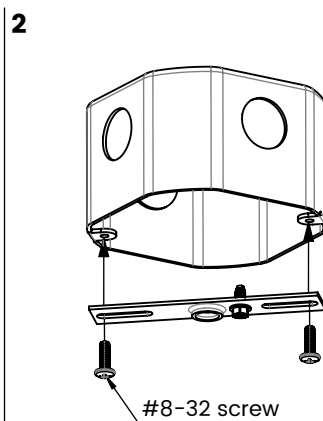

FIGURE 3

Attach the crossbar to the junction box using provided #8-32 screws.

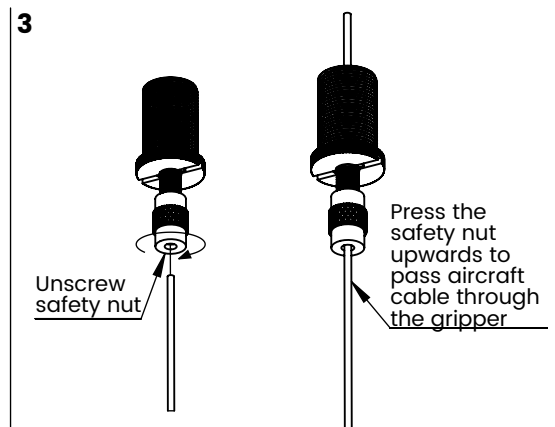

FIGURE 4

Partly loosen safety nut on cable gripper. Feed aircraft cable through the gripper.

**4-A - SINGLE REMOTE DRIVER**

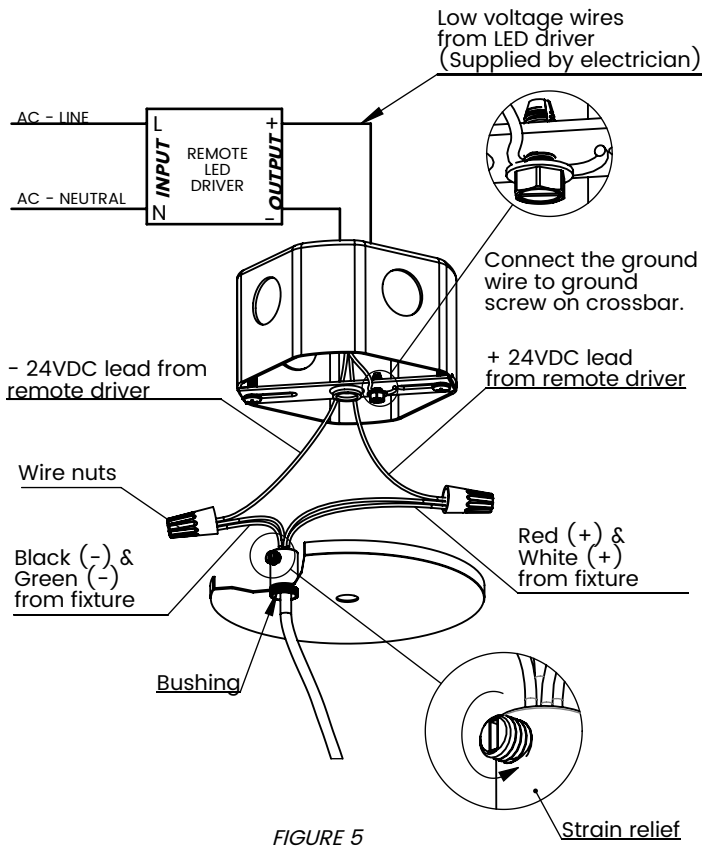

FIGURE 5

Loosen the screw on the strain relief and pass power cable through bushing and strain relief as shown. Connect wires according to diagram (wire nuts provided). **Length of power cord should be adjusted for desired suspension height. Tighten the screw on the strain relief after adjustment.**

**You may require assistance holding the light fixture while making wire connections.**

**Wires to and from the driver are not provided.**

**4-B - TWO REMOTE DRIVERS INDEPENDENT (DIRECT/INDIRECT) DIMMING**

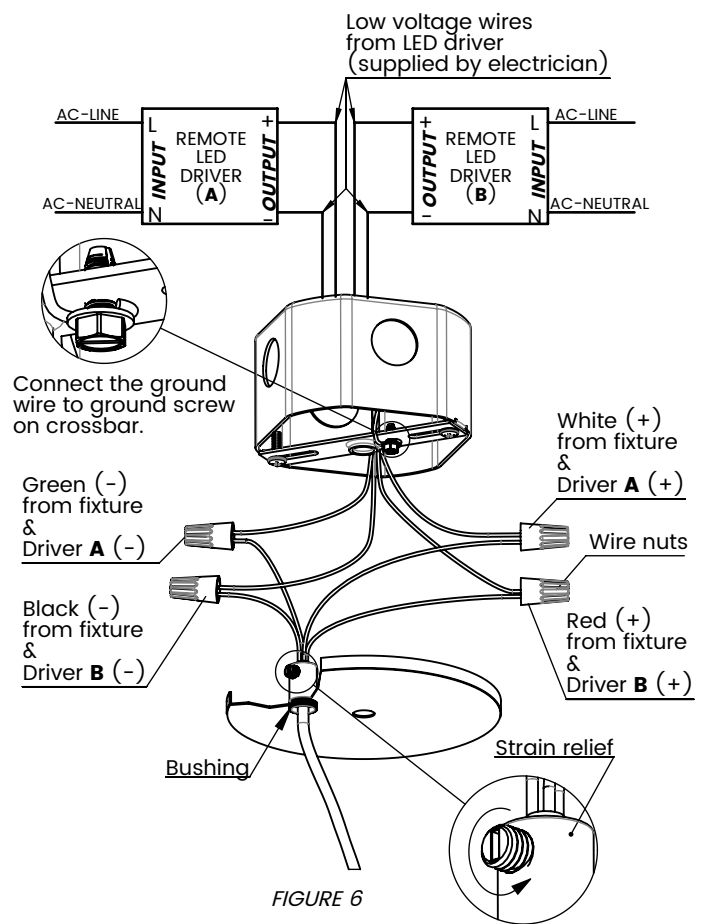

FIGURE 6

**LED DRIVER A controls direct light and LED DRIVER B controls indirect light.**

Loosen the screw on the strain relief and pass power cable through bushing and strain relief as shown. Connect wires according to diagram (wire nuts provided). **Length of power cord should be adjusted for desired suspension height. Tighten the screw on the strain relief after adjustment.**

**Wires to and from the driver are not provided.**

**5**

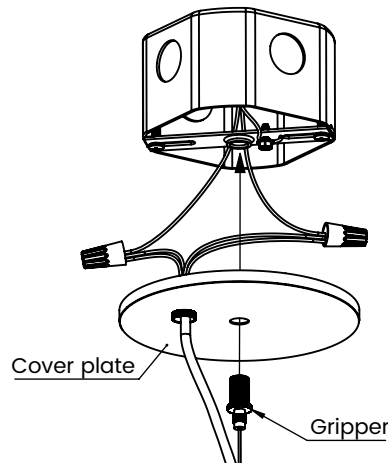

FIGURE 7

Screw gripper into crossbar to attach cover plate to the junction box.

**CEILING POST (B)**

6

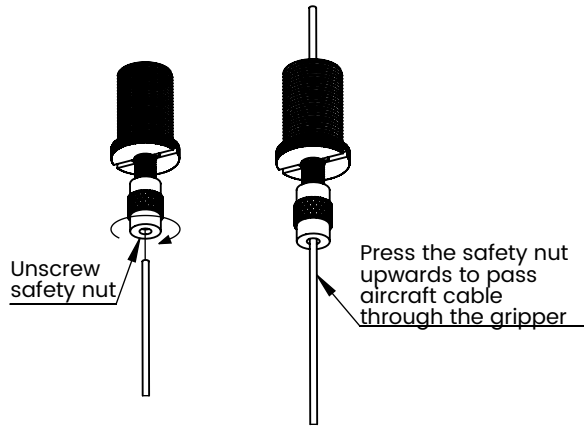

FIGURE 8

Partly loosen safety nut on cable gripper. Feed aircraft cable through the gripper.

8

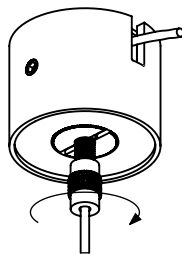

FIGURE 10

Adjust aircraft cable length as needed. Press safety nut on gripper to loosen aircraft cable. Tighten safety nut in completely when finished. **Do not cut extra aircraft cable until full fixture is assembled and desired suspension height is achieved.**

7

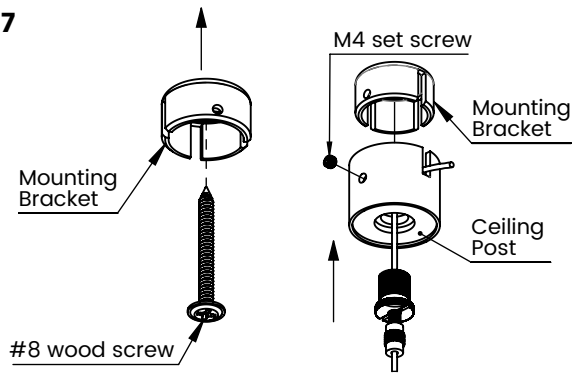

FIGURE 9

Install mounting brackets at mounting point B using provided #8 wood screw. Pass the extra aircraft cable through the slot in ceiling post and screw gripper into ceiling post. Attach ceiling post to mounting bracket using provided M4 set screw. Alternate screws may be used at the recommendation of an electrician.

**Use the slot on mounting bracket to make finer adjustment to mounting positions.**

**STEP 3: CONSTRAINING THE POWER CORD**

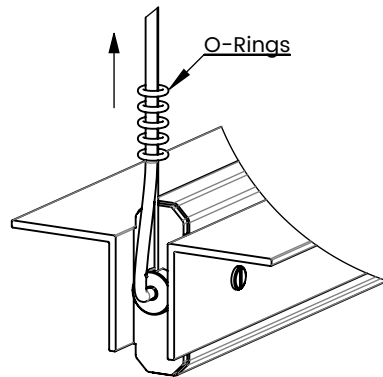

FIGURE 11

Space the O-rings apart at the power end along the length of the cable to constrain the power cord to aircraft cable.

**CARE INSTRUCTIONS**

Brass will patina over time like other natural metals and regular care is required in order to retain the quality finish of your fixture for years to come.

Gently wipe with a damp cloth to remove dirt, dust, and fingerprints.

Do not use any chemical cleaning solution.

Use indoors only.